

Technical Specification

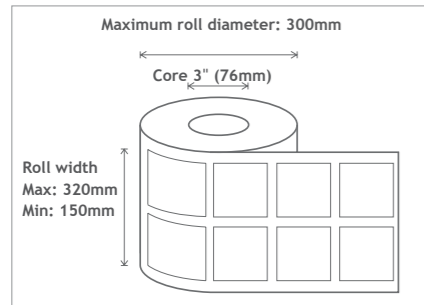

Intec LCF500 Pro Roll to Roll Label Cutter

| | |
|--|---|
| Maximum label frame length | 420mm (16.53") |
| Mandrel core diameter | 76mm (3") |
| Maximum input & output roll diameter | 300mm (13.78") |
| Max speed/Max force | 10 - 1200mm sec / 750gf |
| Material web width | 150mm up to 320mm |
| Label sizes | Max width: 330mm. Max Length: 280mm. Min length: 20mm |
| Registration system | 1, 2 or 4 marks with Vision3 - High resolution CCD vision system ARMS 9 |
| Job retrieval | Direct from PC or HELD within cutter for production environments |
| Contour cutting | Full HPGL vector cutting compatible with PageMark CCD sensor |
| Mountable tools | Single tool holder supports cutting blades (30°, 45° & 60°) and pen calibration tool for auto-calibration |
| Cut position accuracy | +/- 100 micron |
| Slitting | 7 Rolls, using up to 6 blade slitting - supplied |
| Lamination | Inline lamination when required |
| Rewind mandrels | One - matrix removal |
| Weight (unpacked) | 397kgs |
| Dimensions W, D, H | 1,720mm x 930mm x 1,330mm |
| Power Supply | 220~240V AC, 50/60Hz, 350W, 3.4A |
| Software and PC Specification | |
| Minimum PC specification | Windows® 10/11 Pro x64 bit. 4GB of RAM (8GB recommended). Monitor res: 1280 x 960 min |
| ColorCut Pro 5 Plugin [§] - PC | Adobe® Illustrator® 2017 - 2025 or CorelDRAW® 2017 - 2024 Graphics Suite |
| ColorCut Pro 5 Plugin [§] - Mac Client | Adobe® Illustrator® 2022 - 2025. Mac operating systems: Catalina to Sequoia |
| ColorCut Pro 5 Standalone [‡] - PC Only | Job server - enables jobs created by the ColorCut Pro Plugin above to be cut at any time |

[§] Does not support illegal copies of Illustrator. [‡] Full version only. Does not support 'Home and Student', 'Essentials' edition, or illegal copies of CorelDRAW.

* Maximum dimensions relate to assembled machines and reflect full extremities of each device.



Genker Str. 10 · 53842 Troisdorf
 Telefon +49 (0) 2241-23417-30
 Telefax +49 (0) 2241-23417-55
 mail@mehringgmbh.de
 www.druckweiterverarbeitung.de

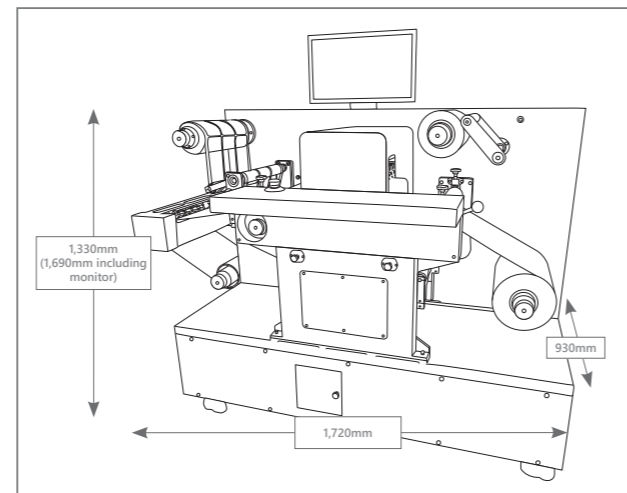

Intec LCF500 Pro Roll-to-Roll Label Cutter Finisher



***Disclaimer** As part of our continued product improvement plan, specifications and information published here are subject to change without notice. All specifications are dependent on application, type of stock, temperature, RH and print engine used. Specifications quoted were measured on uncoated and unprinted stock. E & OE.

Fully automated, ultra fast roll-to-roll label production, with the ColorCut LCF500 Pro.

The LCF500 Pro system offers an all-in-one on demand label complete finishing solution for volume roll label production.

This incredibly versatile solution provides easy roll loading to cut and finish any shape of label with the option to laminate your label rolls, remove the waste matrix and slit into narrower finished rolls where needed.

Market leading features

- Digital process means no more costly dies
- Roll widths of 150mm, 215mm up to 320mm wide and up to 300mm diameter
- Select from one to four PageMark registration points, enabling you to set the balance between speed and precision cutting
- Lamination provides your finished labels with surface protection and light fastness
- QR code/Job Library retrieves associated cut files - even for mixed batch production
- Linear cutting speeds up to 10.5m/min dependent on label design and roll width*
- Automatic tracking technology continually measures roll position to dynamically adjust for rewind accuracy
- Customisable matrix removal control settings
- Convert rolls with final job slitting - up to 7 rolls
- Run jobs from computer or from a USB drive

*see productivity support sheet

Fully automated for unattended production

The LCF500 Pro system combines robust engineering with precision registration for instant job retrieval. Its patented auto-tracking technology continually monitors roll position, dynamically and actively adjusting the roller mandrel axis to deliver exceptional cutting accuracy and consistent finishing quality.

Designed for simplicity, roll loading is quick and intuitive and with dual accumulator arms, the printed roll moves seamlessly backwards and forwards, enabling accurate cutting of virtually any shape label. The integrated lamination station allows users to apply a protective film automatically, adding both scratch and water resistance to labels. An acoustic muffling bar reduces operating noise during lamination, making the LCF500 Pro suitable for use in an offices and design studios.

Powered by ColorCut Pro 5 software, the system reads printed PageMarks and QR code for instant cut-file retrieval. Users can select between 1, 2 or 4 PageMark recognition to strike the perfect balance between speed, productivity and precision.

A stand out feature, the intelligent auto tracking system, constantly monitors the roll edge and corrects any deviation, ensuring every finished label roll has perfectly aligned cut elements.

Ai makes control easier

The LCF500 Pro is built on the foundation of Intec's next generation of Ai (Applied Intelligence) ColorCut software which delivers a host of new features together with the functionality and control you need.

Cutting directly from ColorCut Pro offers unparalleled flexibility and control over cutting and production enabling all options to be adjusted on the fly with the integrated job controller with comand center display.

Software

ColorCut software enables designers to simply generate cut files with registration marks and QR codes with associated job numbers as part of the design process.

ColorCut Pro explained

ColorCut Pro consists of two parts, the first is the ColorCut Pro Client, a plug-in to Adobe® Illustrator® for Mac or PC creatives or to CorelDRAW® (PC only). This enables designers/artworkers to generate cut files without the need to learn any new applications. The ColorCut plug-in also adds the ability directly into your graphics application to add both cut registration marks and QR codes with associated job numbers, easily, simply and as an integral part of the design process. It also saves each cut job into a ColorCut Pro job library for instant retrieval at any time, now or in the future.

Adding the QR codes and job numbers, is a key part of the ColorCut Pro magic, with QR codes the LCF500 Pro is able to retrieve previously prepared cut files without the need to launch Adobe® Illustrator® or CorelDRAW®. In fact this means, that after a graphic designer has sent the job to print, in a production print environment, any user can collect the rolls from the printer and cut them without needing to trouble the graphic designer to ask what cut file to use, or where it is stored

Auto scan QR code and registration marks

Cut file acquisition and job placement The cutters in-built camera reads the printed QR code to automatically retrieve the associated cutting file from the ColorCut Pro Job Library. It also scans the printed PageMarks for precise positioning, with advanced features compensating print or alignment skew to ensure perfect cut registration.

QR driven workflow

Process single/multiple or mixed jobs in the same run. The QR workflow offers significant advantages by automatically retrieving the correct cut file for every job printed on the roll. This allows each job to be completely unique, enabling seamless processing of mixed jobs in a single pass.

